

RTF 系列

油箱顶置回油过滤器

流量 最大1200L/min

工作压力 最大16bar



性能参数 Specifications

结构形式：油箱顶置	Type of construction : Tank top mounted
工作压力：最大 16 bar	Operating pressure: Max. 16 bar
连接形式：BSPP/M螺纹,SAE法兰	Connections: Threaded BSPP/Metric, Flanges SAE
密封材料：丁腈橡胶，氟橡胶，	Seal material: NBR,Viton, EPDM on request
工作温度：-40℃ ~ +120℃	Operating temperature range: -40℃ to +120℃
过滤材料：玻纤，滤纸和金属网	Filtration media: Glass fibre, Cellulose and Wire Mesh.
滤芯爆破压力：10 bar	Element collapse rating: 10 bar (ISO 2941)
旁通阀开启压力：4 bar	Bypass setting: Opening pressure 4 bar
发讯器报警压力：	Pressure indicator options:
压力表-压力开关（常开）3.5 bar	Pressure gauge – Pressure switch (N.O.) 3.5 bar
壳体材料：铝	Filter housing: Aluminium head and cover
工作介质相容性：	Fluid compatibility: Suitable for mineral oils, synthetic .
适用于矿物油，人工合成油，	For use with water, please contact
其它介质咨询公司技术部门。	our company.

产品液压符号 Hydraulic symbol

回油过滤器
Return filter



订货代码 Ordering Code

过滤器 The completed filter

RTF 0630 F 010 N F90 V

过滤器型号 Filter type

流量 Flow rate (L/min)

0025, 0040, 0063, 0100, 0160, 0250, 0330,
0400, 0500, 0630, 0800, 1000, 1200

滤芯材料 Element material

P: 滤纸Cellulose ($\beta \times 2$), F: 玻纤Glass fiber($\beta \times \geq 200$), W: 金属网Wire mesh过滤精度 Filtration rating(μm)

(F): 002, 005, 010, 020 (P): 010, 025 (W): 040

密封材料 Seals

N: 丁晴橡胶 NBR, V: 氟橡胶 Viton

接口形式/尺寸 Port type/Size

流量 Flow rate	形式/尺寸 Type/Size												
	B(BSPP 管螺纹 thread)					M(公制螺纹Metric thread)					F(法兰Flange)		
	8	12	16	20	24	18	27	33	42	48	40	63	90
RTF0025	●					●							
RTF0040		●					●						
RTF0063			●					●					
RTF0100				●					●				
RTF0160					●					●	●		
RTF0250					●					●	●		
RTF0330												●	
RTF0400												●	
RTF0500													●
RTF0630													●
RTF0800													●
RTF1000													●
RTF1200													●
B08=G ¹ / ₂ , B12=G ³ / ₄ , B16=G1, B20=G1- ¹ / ₄ , B24=G1- ¹ / ₂													
M18=M18x1.5, M27=M27x2, M33=M33x2, M42=M42x2, M48=M48x2													
F40=SAE 1- ¹ / ₂ ", F63 =SAE 2- ¹ / ₂ ", F90=SAE 3- ¹ / ₂ "													

压差发讯器 Indicators

N: 无No, V: 压力表 Pressure gauge E: 压力开关 Pressure switch 3.5 bar

RTF油箱顶置回油过滤器

RTF Tank Top Return Filter

订货代码 Ordering Code

滤芯 The Replacement Element

RTE 0630 F 010 N

滤芯型号 Element type _____

流量 Flow rate (L/min) _____

0025, 0040, 0063, 0100, 0160, 0250, 0330, 0400, 0500, 0630, 0800, 1000, 1200

滤芯材料 Element material _____

P: 滤纸 Cellulose ($\beta x=2$), F: 玻纤 Glass fiber($\beta x \geq 200$), W: 金属网 Wire mesh

过滤精度 Filtration rating(μm) _____

(F): 002, 005, 010, 020 (P): 010, 025 (W): 040

密封材料 Seals _____

N: 丁晴橡胶 NBR, V: 氟橡胶 Viton

过滤器主要性能参数 Filter Specification

过滤器 Filter	接口 Ports	滤芯 Element	重量 Weight(Kg)
RTF0025	G ^{1/2} , M18x1.5	RTE0025...	0.85
RTF0040	G ^{3/4} , M27x2	RTE0040...	0.9
RTF0063	G1, M33x2	RTE0063...	1.5
RTF0100	G1 ^{-1/4} , M42x2	RTE0100...	1.7
RTF0160	G1 ^{-1/2} , M48x2 SAE 1 ^{-1/2} "	RTE0160...	2.7
RTF0250		RTE0250...	4.35
RTF0330	SAE 2 ^{-1/2} "	RTE0330...	5.77
RTF0400		RTE0400...	6.15
RTF0500	SAE 3 ^{-1/2} "	RTE0500...	7.5
RTF0630		RTE0630...	8.2
RTF0800		RTE0800...	8.9
RTF1000		RTE1000...	9.96
RTF1200		RTE1200...	10.5

压降曲线 Pressure Drop Curves

过滤器的压降是壳体的压降加上清洁滤芯的压降。推荐回油过滤器初始压降不大于0.5bar。

如果所使用的工作介质粘度不是32cSt, 实际压降计算如下:

$$\Delta p = (\Delta p_{32} \times \text{工作介质粘度}) / 32\text{cSt.}$$

过滤器压降数据是基于工作介质的动力粘度32cSt、密度0.87得到。

The "Assembly Pressure Drop(ΔP) is obtained by adding the pressure drop values of the filter housing and of the clean filter element and the recommended level of the initial pressure drop for return filter is less than 0.5 bar.

If the medium used has a viscosity different from 32cSt, pressure drop over the filter can be estimated as follows:

$$\Delta p = (\Delta p_{32} \times \text{viscosity of medium used}) / 32\text{cSt.}$$

Filter pressure drop based on 32cSt fluid viscosity and 0.87 density.

壳体压降 Filter Housing Pressure Drop

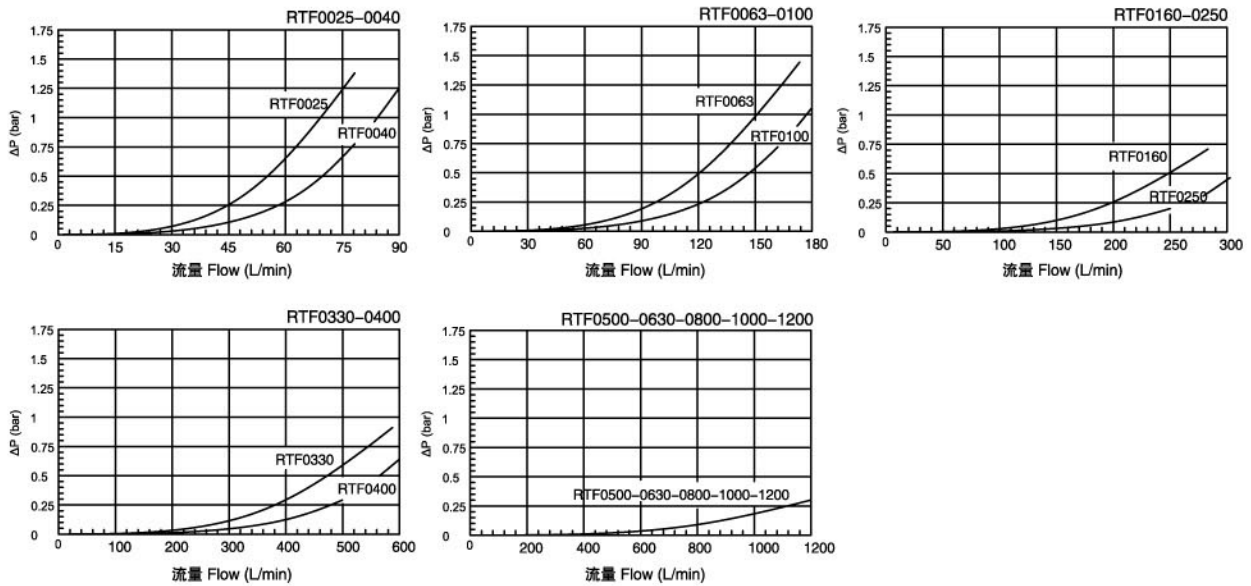

玻纤和滤纸滤芯初始压降

Clean Element Pressure Drop With Media F&P

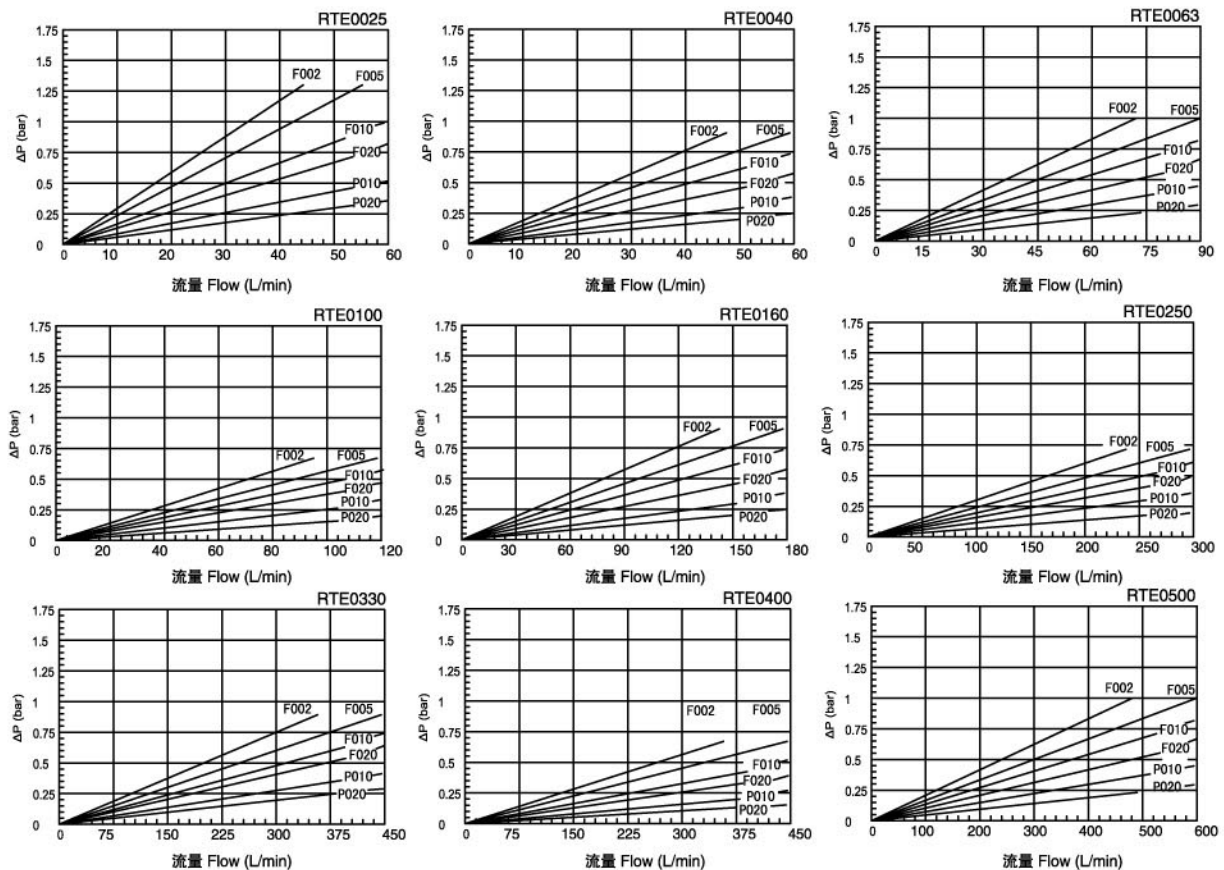

RTF油箱顶置回油过滤器

RTF Tank Top Return Filter

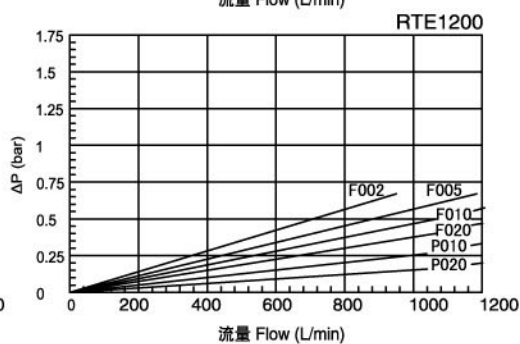
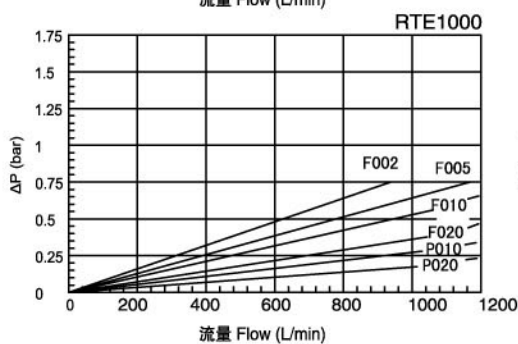
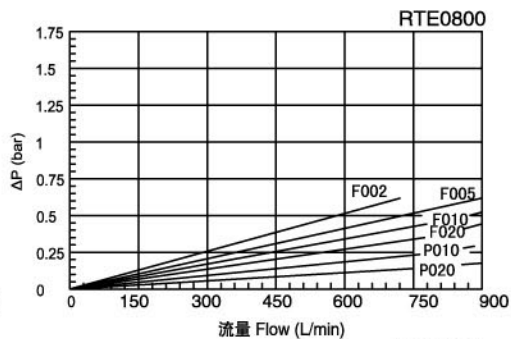
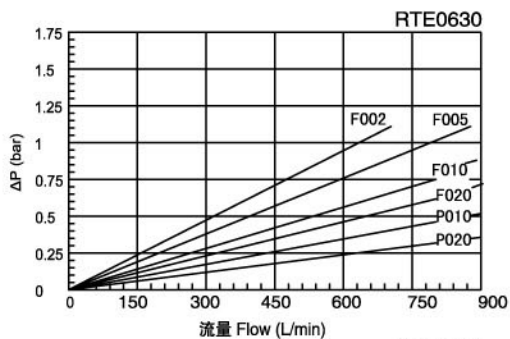

外形安装尺寸 Dimensions

RTF0025-0100

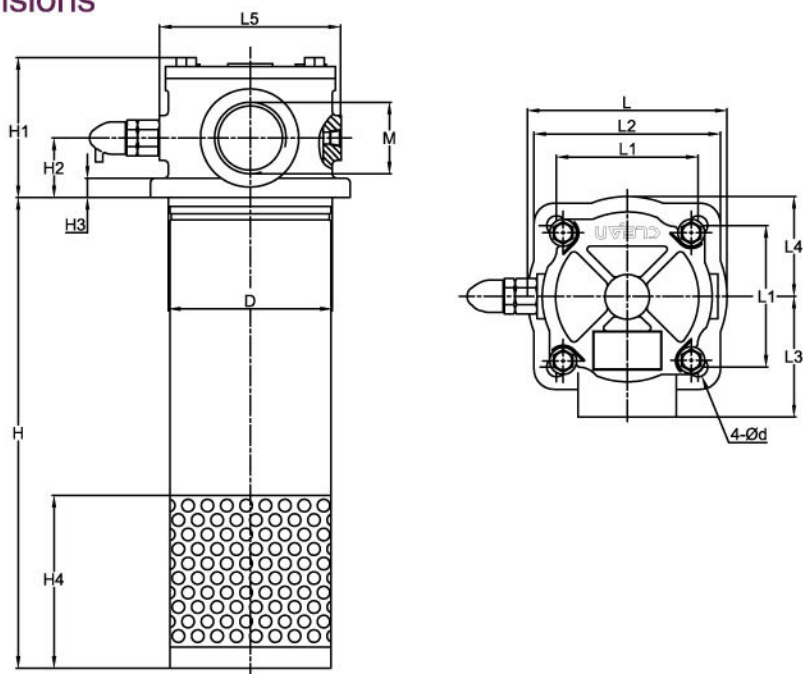

型号 Type	M	D	H	H1	H2	H3	H4	L	L1	L2	L3	L4	L5	d
RTF0025	G1/2, M18x1.5	ø75	127	70	25	10	45	90	70	90	53	45	122	ø9
RTF0040	G3/4, M27x2		158											
RTF0063	G1, M42x2	ø95	185	90	33	12	60	120	85	110	60	60	122	ø9
RTF0100	G1-1/4, M42x2		245											

外形安装尺寸 Dimensions

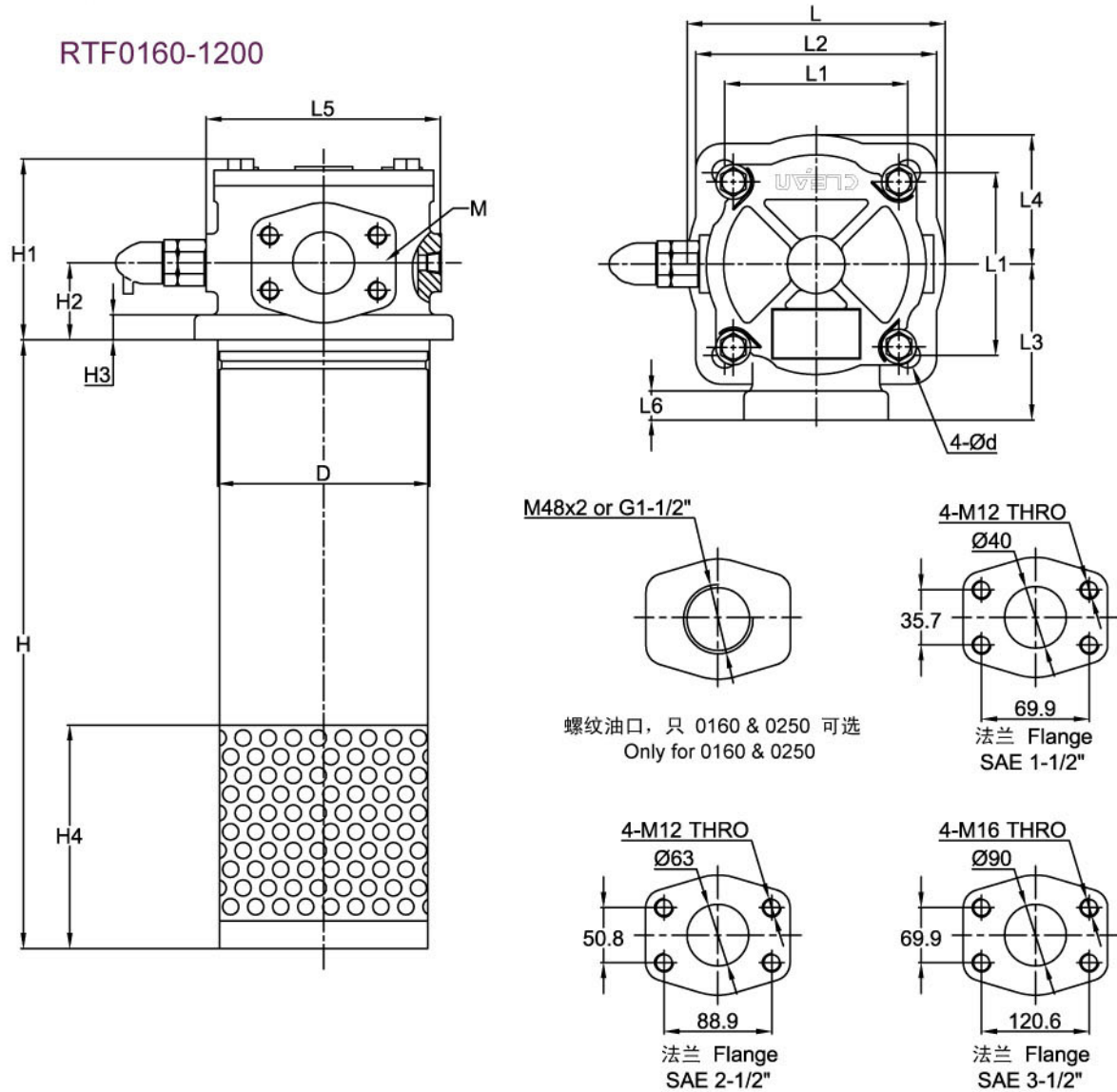

型号 Type	M	D	H	H1	H2	H3	H4	L	L1	L2	L3	L4	L5	L6	d
RTF0160	G1-1/2, M48x2 SAE 1-1/2"	ø110	320	100	40	13	80	134	95	125	85	67	122	15	ø13
RTF0250			420	120											
RTF0330	SAE 2-1/2"	ø130	345	127	55	90	159	110	140	90	79	134			
RTF0400			463												
RTF0500	SAE 3-1/2"	ø160	456	164	70	15	100	192	140	170	110	96	169	18	
RTF0630			484												
RTF0800			594												
RTF1000			774												
RTF1200			974												